

Design Innovation and Static Analysis of Composite Leaf Spring Using Autodesk Fusion 360

Duriseti V. Srikanth^{a,*}, Allam Purushottam^a

^aSNIST, Yamnampet, Hyderabad, Telangana, India.

Keywords:

Design, Fusion 360, Solid, Modelling, Spring

* Corresponding author:

Duriseti Venkata Srikanth 
E-mail: srikanth.d@sreenidhi.edu.in

Received: 6 April 2025

Revised: 22 May 2025

Accepted: 10 June 2025



ABSTRACT

The aim of this study is to create and alter the steel leaf spring design so that it can be used in automobiles for a longer period of time by substituting composite materials. When compared to traditional steel leaf materials like carbon epoxy, aluminum alloy, and titanium alloy have better mechanical qualities and are more cost-effective. The weight-saving features, deformation and stress characteristics of traditional steel and composite leaf springs were verified and compared. Stiffness was a limitation on the design. The remarkable corrosion resistance and excellent strength to weight ratio make composite leaf springs of utmost interest to the automotive industry. Using Autodesk Fusion 360, the leaf spring was modeled and investigated.

© 2026 Journal of Sustainable Development Innovations

1. INTRODUCTION

A leaf spring's main functions are to support a car and provide the ride a smoother quality by cushioning impacts from potholes in the road. Leaf springs are used to locate the axle and control the vehicle's travel height in addition to keeping the tyres aligned on the road. A simple type of suspension consisting of steel or composite layers stacked one on top of the other in different diameters is called a leaf spring. The axle is held in place by the straightforward and sturdy construction of the suspension, which serves as a linkage without the need for additional linkage. Depending on where the back axle is located additional weight and expenses

could be decreased. Leaf springs are perfect for heavy commercial vehicles since they regulate axle damping and sustain the weight of the chassis. According to Patankar et al. [1], understanding the behavior of a composite leaf spring requires an equal amount of attention to the investigation of the composite material. The purpose of this study was to examine the results of mono composite leaf spring (GFRP) modeling, analysis, and testing. Pro-E (Wild Fire) 5.0 was used for modeling, while ANSYS 10.0 was used for analysis in order to gain a deeper understanding. Using normal eyes and cast eye ends, a traditional mono leaf spring was developed and analyzed by Arora et al. [2]. CAD modeling was completed in CATIA, and analysis of the deformation, von

Mises stress, and normal stress parameters was performed in ANSYS under comparable loading conditions. Shokrieh et al. [3] presented their work on the design, analysis, and optimization of a leaf spring. The primary objective of this research was to design a spring that could safely handle the designated static external stresses while weighing the least amount of weight. A four-leaf steel spring, which is a component of the rear suspension system of both light- and heavy-duty cars, was modeled using ANSYS. The findings demonstrated that the steel leaf spring was subjected to substantially greater pressures than the composite leaf spring.

With ANSYS 14.5, Dwivedi et al. [4] investigated a composite leaf spring. There was an E-glass and epoxy three-layer full-length leaf composite leaf spring. The performance of a composite leaf spring and a conventional steel leaf spring was compared. When it came to weight and strength, the epoxy/e-glass composite performed better than the traditional steel leaf spring. Kapadia et al. [5] considered deflection and stress in their design for their experiment. Standard steel, E-glass fiber, and composite Epoxy/E-glass were the materials selected for comparison. The solid modeling of the leaf spring that was finished in CATIA V5 was examined using ANSYS. According to the results of the static study, graphite epoxy outperformed the other materials.

Ashok et al. [6] researched the structure and design of a glass fiber reinforced polymer (GFRP) composite leaf spring. The study aimed to compare the cost-effectiveness, stiffness, and load-bearing capacity of steel and composite leaf springs. Pro-E was used to model a multi-leaf spring using finite elements, and ANSYS-11 was utilized to examine it. Rathore et al. [7] provided evidence of an improved automobile design and application for the usage of parabolic leaf springs as opposed to mono leaf springs. The study's conclusions offered helpful guidance to automakers that wanted to standardize their design and optimization procedures. Jadhao et al.'s work [8] involved changing the material of a leaf spring. The materials selected for this experiment were polyester resin and glass fiber reinforced plastic (GFRP) (NETPOL 1011).

Jacob et al. [9] built and modeled a leaf spring in line with the applied loads. The leaf spring was

constructed out of forged steel. In this work, the reinforcing angle was varied to develop the leaf spring for mild steel and composite glass carbon. The model and fatigue study were also performed using ANSYS and Pro/Engineer. Janarthan et al. [10] evaluated the deflection, stress, and mode frequency that the ordinance factory caused in a Sumo leaf spring design. Finite element experimentation and computer-aided analysis was given particular attention in this research.

2. MATERIALS

2.1 Leaf Spring

Vehicle suspension systems employ leaf springs as shown in figure 1. Originally, they were referred to as laminated or carriage springs.



Fig. 1. Leaf spring (semi elliptical).

They are constructed from thin, arc-shaped steel sections that are connected together to resemble a forced bow. The parts are piled with smaller portions of the same material. The bending concept is the foundation for how a leaf spring operates. Even when the structure resists, bending happens when a load is applied to its ends. Consequently, the reaction force that is produced opposes the applied load, endowing the leaf spring with its characteristic springiness. Because spring steel flexes when pressure is applied at either end and uses its own dampening mechanism to return to its original position, it is typically used in leaf spring setups to create an elliptical shape. Usually, the steel is divided into rectangular pieces and fastened together using a big bolt through the middle of the leaves and metal clips at each head. Table 1 lists the leaf spring geometry and properties used in the analysis. Big U-bolts are used to secure it to the vehicle's axle. The chosen composite materials'

material qualities that were compared to those of steel are listed below.

Table 1. Leaf spring geometry and properties.

| | | |
|---|---------------------------------|---------|
| 1 | Eye to eye length of the spring | 1120mm |
| 2 | Length of Free camber | 180 mm |
| 3 | Qty. of extra Full Leaves | 2 |
| 4 | Leaf width | 50 mm |
| 5 | Leaf thickness | 6 mm |
| 6 | Poisson's Ratio | 0.3 |
| 7 | Modulus of Elasticity of steel | 210 GPa |
| 8 | No of Graduated Leaves | 8 |

2.2 Material selection

Steel, aluminum alloy, titanium alloy, beryllium oxide, and epoxy carbon were the materials that were used.

1. Epoxy Carbon: High specific strength, modulus, and fatigue strength are all present in this material, along with a low coefficient of thermal expansion.
2. Aluminum Alloy: Due to its greater malleability, elastic properties, resistance to corrosion, and lower density, aluminum is a highly sought-after metal.
3. Titanium Alloy: A range of alloys make up titanium, which is known for its remarkable strength, rigidity, low density, toughness and remarkable resistance to corrosion. It is the most robust and practical metal available.
4. Beryllium Oxide: This white, colorless solid has a higher thermal conductivity than any other non-metal, with the exception of diamond. It also functions as a noteworthy electrical insulator.
5. Steel: Typically, leaf springs are composed of 0.90 to 1.0% carbon plain carbon steel. The leaves are heated following the production procedure. Products made of heat-treated spring steel have improved strength, a wider range of deflection, and improved fatigue characteristics, all of which increase the load capacity.

2.3 Solid modelling

Initially, the leaf spring was solidly modeled using Autodesk Fusion 360 in the manner described below. In Fusion 360, the assembly drawing portion is where all of the bolts, clamps, and leaves were put together after being

individually designed in the part drawing. By making surface contact between each leaf's upper and lower surfaces, the leaves were put together. After all the 8 leaves were constructed in this way, the clamps and bolts were subsequently put together in the leaf spring as shown below.

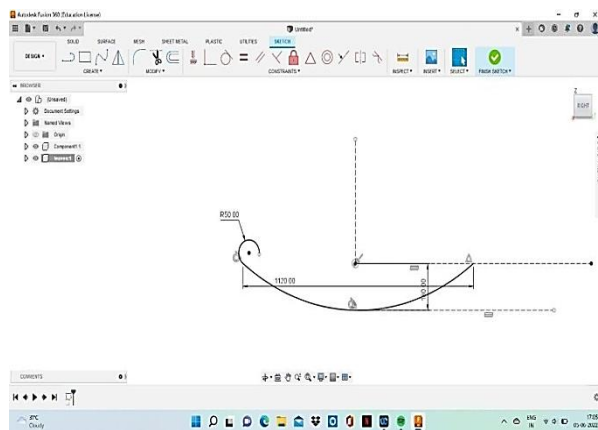

Fig. 2. Arc measuring 1120mm.

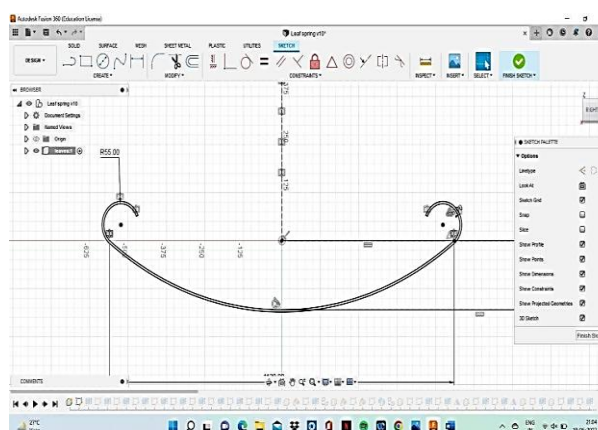

Fig. 3. Eye with radius 55mm.

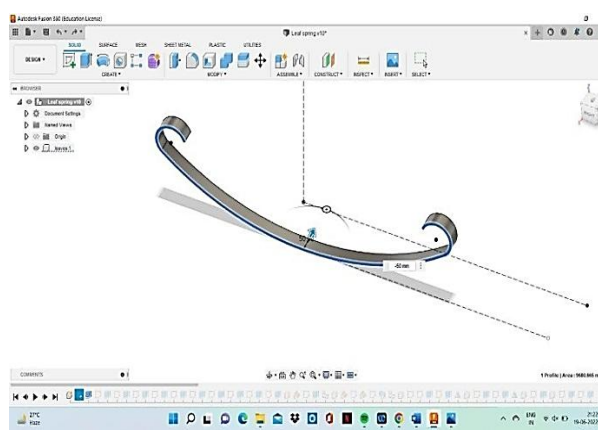

Fig. 4. Extrude operation using 50mm.

1. As shown in figure 2, an arc measuring 1120 mm in length and 180 mm in camber was drawn symmetrically to the construction line.
2. In figure 3, an eye with a radius of 55 mm and an offset curve with a length of 6 mm are drawn and connected. Using a 50 mm dimension, the extrude operation was carried out as shown in figure 4.
3. The same techniques as stages 2 and 3 were used to generate the eight graduated leaves and two additional full-length leaves shown in figure 5.
4. In Figure 6, four circles with a diameter of 10 mm are drawn inside a rectangular box that measures 110 by 70 mm on the bottom leaf.

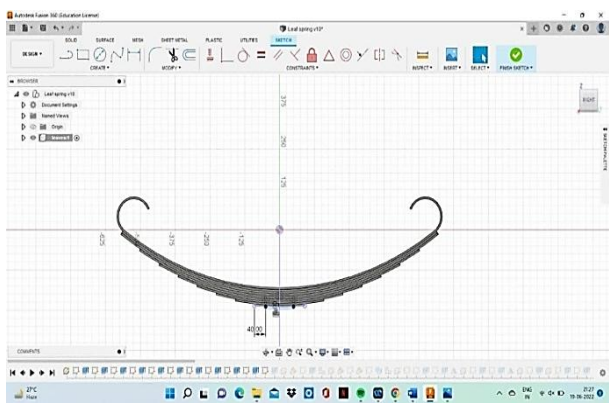

Fig. 5. Graduated and 2 full length leaves.

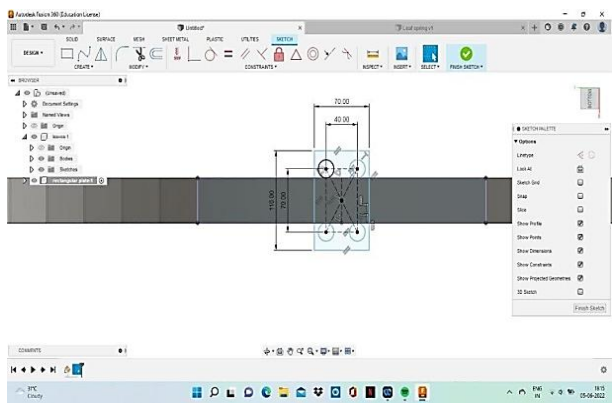

Fig. 6. Circles of 10mm diameter.

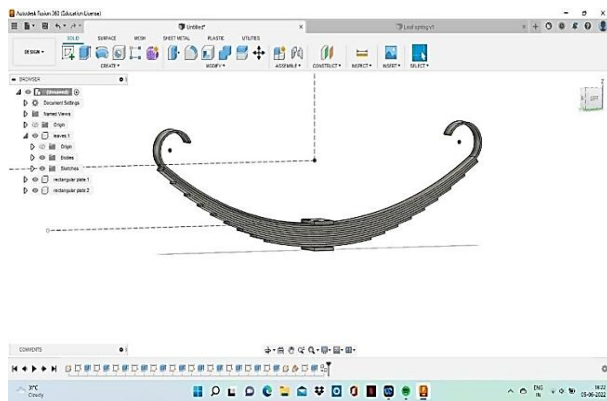

Fig. 7. Rectangular box measuring 76mm.

5. The rectangular box, which was free of the four circles, was extruded to a length of 10 mm before being positioned above the leaves, as seen in figure 7, where it measured 76 mm.
6. In figure 8, a U-bolt was drawn between the two circles with the aid of the sweep operation. It was then moved into the remaining two holes by a length of 75 mm.

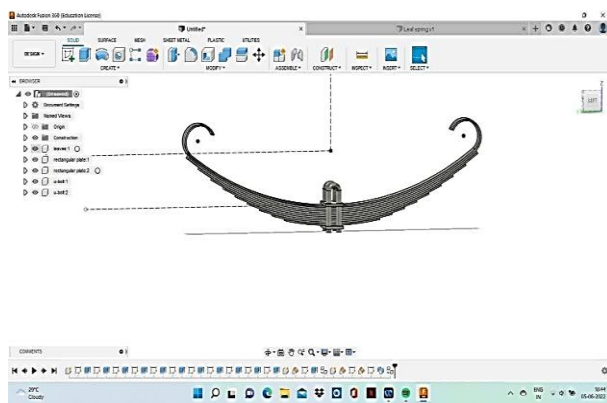

Fig. 8. U bolt drawn using sweep operation.

7. Using the offset and extrude operations in figure 9, a rebound clip of 30 mm length was positioned on one of the leaf edges that was chosen.

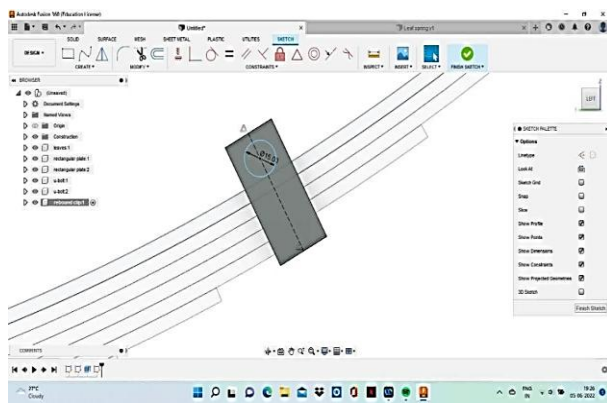

Fig. 9. Rebound clip positioning.

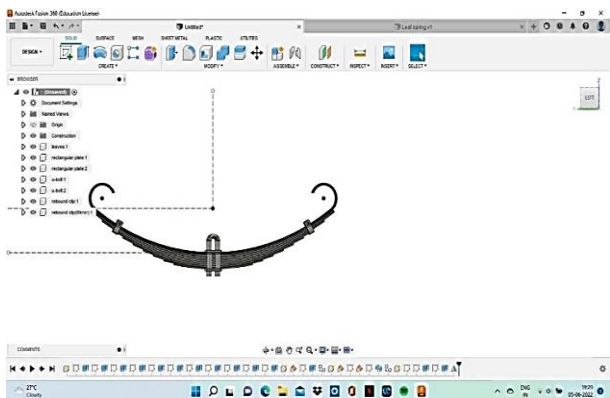

Fig. 10. Mirroring of rebound clip.

8. The extrude operation was used to create two 10 mm diameter holes on either side of the rebound clip, as shown in figure 10. The construction line produced in step 1 was then used to mirror the rebound clip.
9. The rebound clip depicted in figure 11 was created by using the same procedures as in stages and 9.

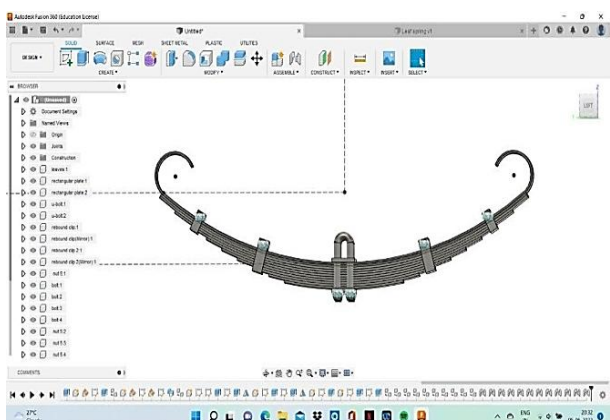

Fig. 11. Rebound clip.

10. As seen in figure 12, eight hexagonal nuts and four hexagonal bolts were made. The four hexagonal nuts that surround the U-bolts were subjected to the join operation, while the remaining components were employed at the rebound clips. This produced the necessary solid leaf spring model.

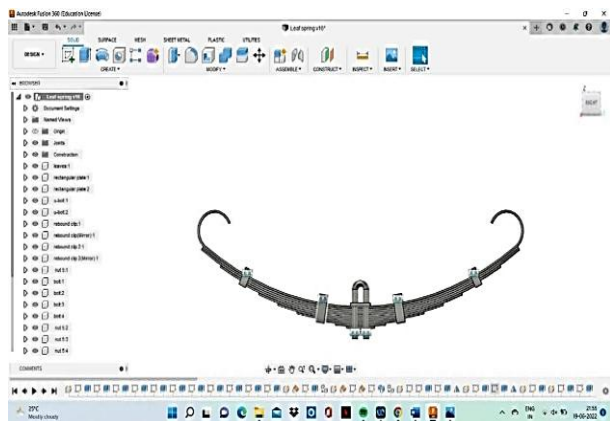

Fig. 12. Leaf Spring model

2.4 Simulation procedure

The materials used in this analysis of leaf springs included steel, titanium alloy, aluminum alloy, epoxy carbon, and beryllium oxide. These resources were chosen from Autodesk Fusion 360 Software's engineering data repository. Clicking on Create Study selected the static study. A 3200N structural load was placed on the bottom rectangular plate's face. By activating the structural limitations, the spring's two eyes locked. It was designed to create the mesh that splits the drawing into a limited number of pieces. By selecting the "generate results" option, the solutions for the stress, deformation, and elastic strain were found. A comparable verified analysis of the stress and deformation of a thrust bearing pad was conducted by Srikanth et al. [11] using ANSYS.

The tension, elastic strain, and displacement values from Fusion 360 were shown as follows. Plots of the aforementioned parameters for ordinary steel, aluminum alloy, titanium alloy, epoxy carbon, and beryllium oxide leaf springs are shown in Figures 13-15, 16-18, 19-21, 22-24, and 25-27 in that order.

The stress, elastic strain, and displacement values for leaf springs made of steel, aluminum alloy, titanium alloy, epoxy carbon, and beryllium oxide (ceramic) are shown in the following table 2.

Table 2. Result analysis.

| Element | Weight(G) | Displacement (mm) | Stress (Mpa) | Elastic Strain |
|--------------|-----------|-------------------|--------------|----------------|
| Epoxy Carbon | 4038.8 | 0.3556 | 39.14 | 0.001883 |

| | | | | |
|-----------------|---------|---------|-------|-----------|
| Titanium Alloy | 13258.4 | 0.01738 | 6.409 | 9.02E-05 |
| Aluminium Alloy | 8230.9 | 0.02845 | 6.256 | 1.448E-04 |
| Beryllium Oxide | 9404.6 | 0.0069 | 8.223 | 2.835E-05 |
| Steel | 23930.7 | 0.01026 | 6.913 | 5.095E-05 |

3. STEEL

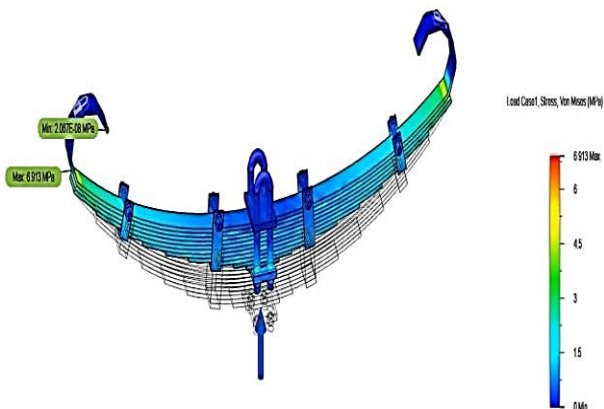

Fig. 13. Steel stress concentration.

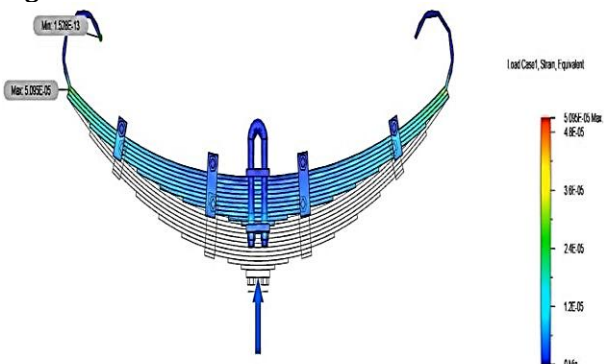

Fig. 14. Steel 7 strain distribution.

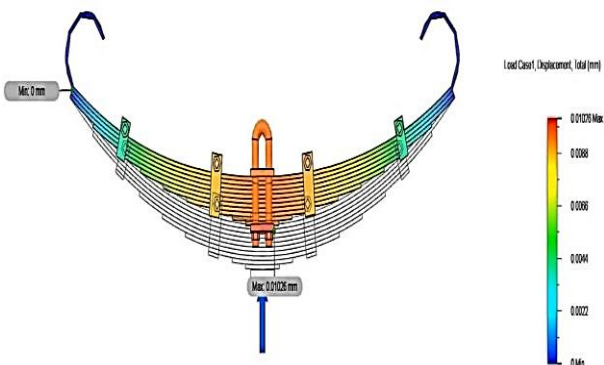

Fig. 15. Steel displacement distribution.

4. ALUMINIUM ALLOY

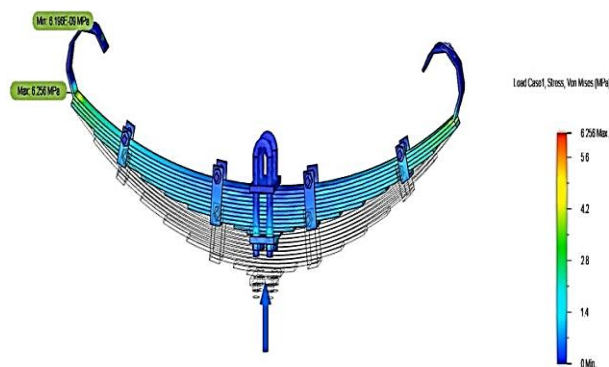

Fig. 16. Aluminium alloy stress concentration.

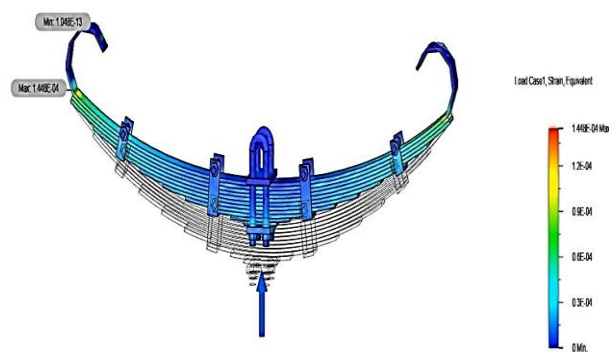

Fig. 17. Aluminium alloy strain distribution.

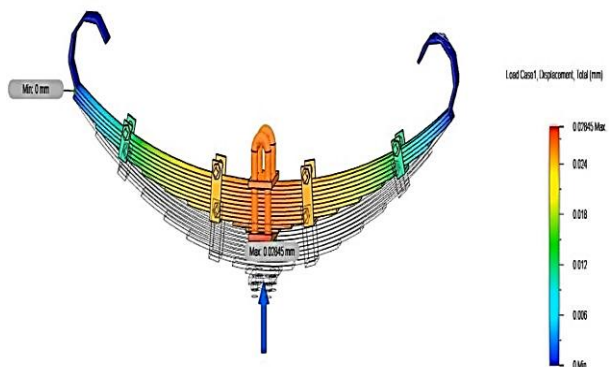

Fig. 18. Aluminum alloy displacement distribution.

5. TITANIUM ALLOY

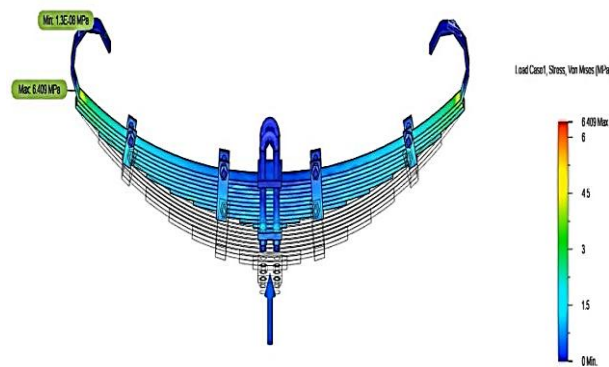

Fig. 19. Titanium alloy stress concentration.

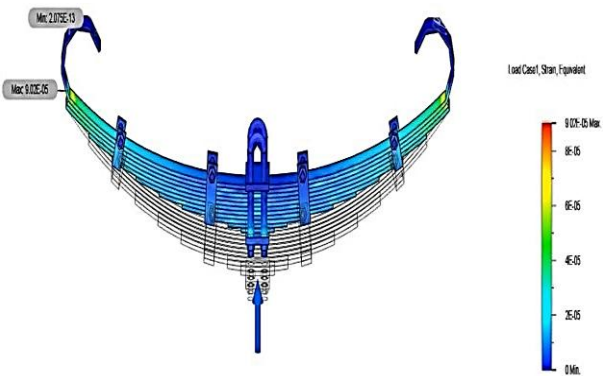

Fig. 20. Titanium alloy strain distribution.

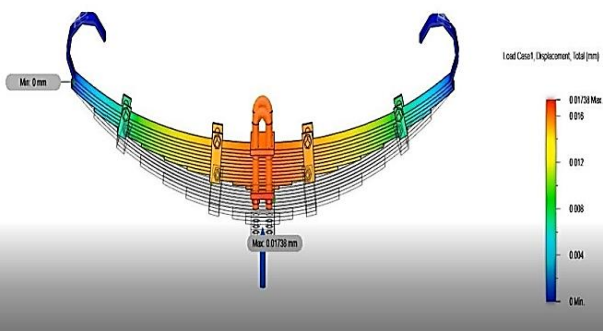

Fig. 21. Titanium alloy Displacement distribution.

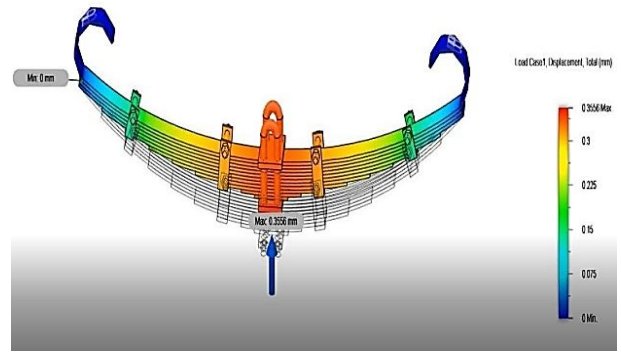

Fig. 24. Epoxy carbon Displacement.

7. BERYLLIUM OXIDE

6. EPOXY CARBON

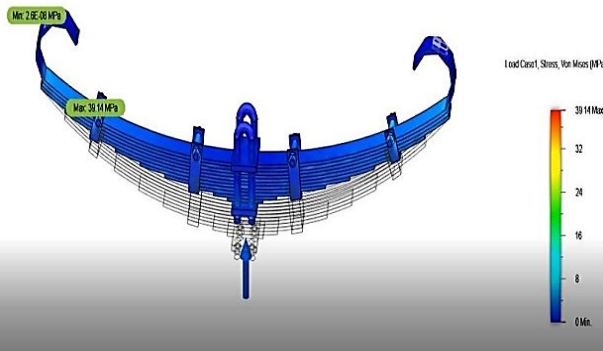

Fig. 22. Epoxy carbon stress concentration.

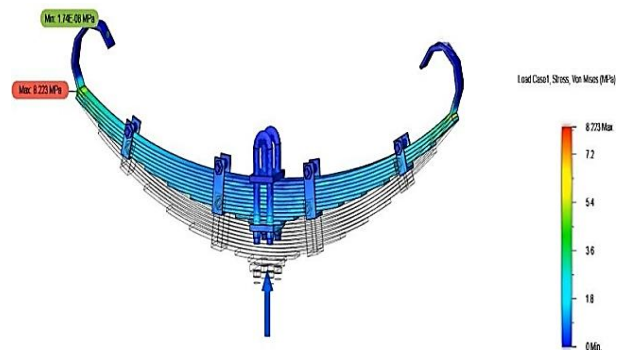

Fig. 25. Beryllium oxide stress concentration.

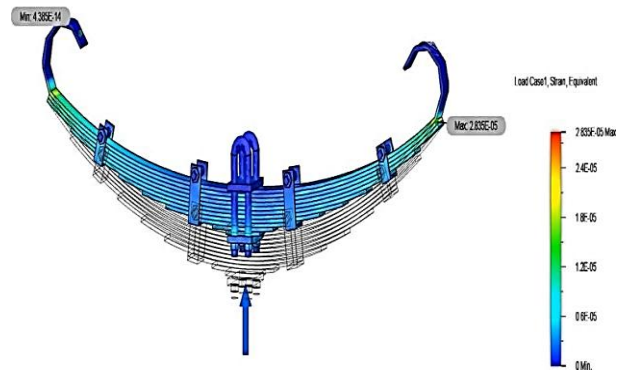

Fig. 26. Beryllium oxide elastic strain.

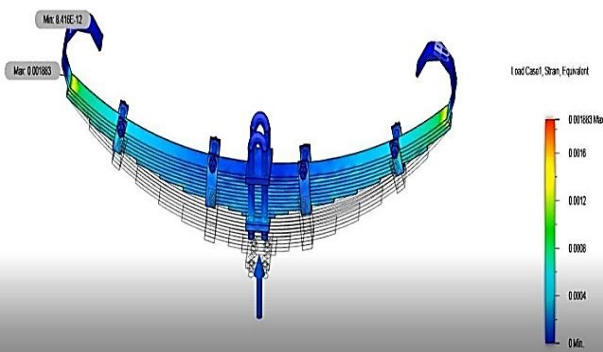

Fig. 23. Epoxy carbon Elastic Strain.

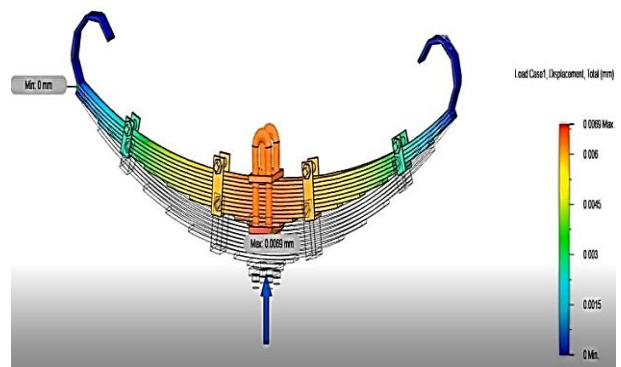

Fig. 27. Beryllium oxide displacement.

8. CONCLUSION

A static investigation of the leaf spring was carried out utilizing several material combinations and similar stress conditions for each design scenario. For every one of these leaf spring design cases, results were obtained for individual parameters. For a variety of material combinations in different leaf spring design scenarios, the results of elastic strain, total deformation, Von-Mises stress, and mass were evaluated. An examination of leaf springs constructed of various materials revealed that the composite epoxy carbon exhibits more

stress for a given load than ordinary steel material. Since weight was a major factor while building cars, epoxy carbon turned out to be more effective than steel due of its lower weight.

REFERENCES

- [1] M. M. Patankar and D. R. Dolas, "Modelling and analysis of composite leaf spring under the static load condition by using FEA," *Int. J. Mech. Ind. Eng.*, vol. 1, no. 1, pp. 1-4, 2011.
- [2] V. Arora, G. Bhushan, and M. L. Aggarwal, "Eye design analysis of single leaf spring in automotive vehicles using CAE tools," *Int. J. Appl. Eng. Technol.*, vol. 1, no. 1, pp. 88-97, 2011.
- [3] M. Shokrieh and D. Rezaei, "Analysis and optimization of a composite leaf spring," *Compos. Struct.*, vol. 60, no. 3, pp. 317-325, 2003.
- [4] D. D. Dwivedi and V. K. Jain, "Design and analysis of automobile leaf spring," *Int. J. Comput. Eng. Sci. Res.*, vol. 3, no. 1, pp. 100-105, 2016.
- [5] D. Kapadia, P. Desai, and A. Sonani, "Design and analysis of composite leaf spring for light weight vehicle," *Int. J. Eng. Sci. Res. Technol.*, vol. 5, no. 6, pp. 666-672, 2016.
- [6] D. Ashok, M. V. Mallikarjun, and V. M. Ramesh, "Design and structural analysis of composite multi leaf spring," *Int. J. Eng. Trends Eng. Dev.*, vol. 5, no. 2, pp. 30-37, 2012.
- [7] R. K. Rathore, E. N. Karlus, and R. L. Himte, "Weight optimization of mono parabolic leaf spring," *Int. J. Adv. Eng. Technol.*, vol. 7, no. 1, pp. 283-291, 2014.
- [8] K. Jadhao and R. S. Dalu, "Experimental investigation and numerical analysis of composite leaf spring," *Int. J. Eng. Sci. Technol.*, vol. 3, no. 6, pp. 4759-4764, 2011.
- [9] G. J. Jacob and M. Deepak, "Design and analysis of leaf spring in a heavy truck," *Int. J. Innov. Technol. Res.*, vol. 5, no. 4, pp. 7041-7046, 2017.
- [10] E. Janarthan and M. Venkatesan, "Design and experimental analysis of leaf spring using composite materials," *Int. J. Eng. Res. Technol.*, vol. 2, no. 12, pp. 1957-1962, 2013.
- [11] D. V. Srikanth, K. K. Chaturvedi, and A. C. Reddy, "Determination of pad thickness in a large thrust bearing," *J. Tribol. Surf. Eng.*, vol. 3, no. 1-2, 2013.